



**CITY OF LAKEWOOD**  
 Building and Safety Division  
 5050 Clark Avenue, Lakewood, CA 90712  
 (562) 866-9771, Extension 2350

**Disclaimer:** Permits are public records and may be posted to the Internet for Public review.  
 Check the boxes below to acknowledge the submittal.

## CHECKLIST FOR SMALL-SCALE SOLAR ENERGY PERMIT

### SECTION 1: REQUIRED PLAN SPECIFICATIONS

Please provide **three (3) copies** of plans as specified in this section (including all listed details) when submitting hardcopies for plan review.

**Site plan (minimum 11"x17") showing:**

- Project address
- North arrow
- Scale
- Roof plan
- Solar panel location, with dimensions from edges and panel dimensions
- Dimensioned depiction of all disconnects and other equipment on the roof
- The path of all wiring

**Dimensioned depiction and of all conduits, piping, or wiring on the roof, subject to the following guidelines:**

- Visible conduits, piping, or wiring shall be minimized to the extent feasible.
- Generally, wiring shall be routed under the panel into the roof and through the attic.
- No conduit, piping, or wiring shall be permitted to extend over a roof ridge.
- If there is no attic, then panels shall be sited to minimize conduit runs across the roof to the extent feasible.
- No conduit shall be permitted to wrap around a roof eave; instead, conduits shall be routed through the roof eave to the vertical wall below.
- All conduits permitted in the guidelines above shall be painted to match the color of the surface on which they are mounted. Unpainted or reflective metal shall be prohibited.

**Location of trees on the subject property**

**Complete building elevations (minimum 11"x17") showing:**

- All affected elevation views (minimum 3 out of 4 elevation views) drawn to scale
- Scale
- Dimensioned depiction of all electrical panels, meters, and other equipment associated with the solar energy system, subject to the following guidelines:
  - Generally, electrical panels, meters, and other equipment shall be painted to match the color of the surface on which they are mounted.
  - If any equipment cannot be painted:
    - Provide documentation explaining why it cannot be painted, and
    - Indicate the actual color in which it will be installed.
- Dimensioned depiction of all conduits, piping, or wiring on exterior walls, subject to the following guidelines:
  - Vertical conduit runs shall be sited and located in such a manner to minimize visibility from public streets and, if feasible, from adjacent properties, such as along a chimney, along a rain gutter, along an architectural projection, or at the intersection of two building planes. To the maximum extent feasible, conduits shall not run vertically across the middle of a flat stucco plane, but rather at the plane edges or at prominent architectural transition areas. If no such architectural transition areas exist, the conduit shall be run across the shortest vertical

distance. (See Exhibit A attached to this checklist.)

- Horizontal conduits, if needed in order to connect the wiring from the attic/roof to the vertical conduit, shall run immediately adjacent to and under the roof eave to arrive at the preferred vertical conduit location described above, so as to minimize visibility. If running adjacent to and under the roof eave is infeasible, then the horizontal conduit shall run along the base of the building as described below.
- Horizontal conduits that connect the vertical conduit to electrical panels shall run along the base of the building above the weep screed or, if infeasible, as low as possible below the height of the perimeter block walls.
- All conduits shall be painted to match the exterior walls on which they are mounted.

**Solar panel installation showing:**

- Manufacturer's specifications
- Panels, pins/posts, mounting hardware, and electrical connections drawn to scale
- Dimensioned depiction of the panel mounting, subject to the following guidelines:
  - Generally, panel installations shall have a low-profile, flush-mounted design.
  - The smallest gap feasible is encouraged between the solar panel and the roof material, and said gap shall be a maximum of 6".
  - If the roof is flat and the solar panels cannot be parallel to the roof, and if the solar panels are visible from a public street, the design shall provide screening along the entire underside of the solar panels (from edge to edge), with the screening painted to match the color of the solar array frame. (See Exhibit B attached to this checklist.)
  - Approved screening materials for flat-roof installations visible from a public street include metal mesh and wood lattice. A sample shall be submitted to the Department of Community Development concurrent with the submittal of the plans.
- Roof materials and connections
  - Generally, the portion of the roof under the solar panels shall not be changed to a different material than the remainder of the roof. Include a depiction and clear written indication that the roof material shall remain consistent across the entire roof.
  - If a different roof material is needed under the solar panels, it shall not be visible. Provide documentation explaining why the different roof material is needed and attach a Residential Re-Roofing (Building Permit) Application for the new material, which is available on the City of Lakewood's website (see link at the below). If the solar panels are removed in the future, please note that all roof materials are required to match in color, size, and material.
  - Include a depiction and clear written indication that portions of the mounting hardware that are visible shall be painted to match the adjoining equipment (specify the color). Unpainted or reflective metal shall be prohibited.

**Completed standard electrical diagram for small-scale, single-phase PV systems:**

- See example in the attached Exhibit C and Exhibit D

**SECTION 2: BUILDING AND SAFETY PERMIT APPLICATIONS AND FORMS**

- Small-Scale Solar Energy Permit Application (Under 10 kW)
- Work Declaration
  - Licensed Contractor
  - Owner-Builder
- Owner's Acknowledgment and Verification of Information (Owner-Builder only)
- Electrical Permit Application (applicable for the alteration/addition of electrical meters or other work)
- Plumbing Permit Application (applicable only for water-heating systems)

All Building and Safety permit applications and forms can be downloaded from the City of Lakewood's website:

[www.lakewoodcity.org/services/forms/default.asp](http://www.lakewoodcity.org/services/forms/default.asp)

**SECTION 3: ACKNOWLEDGEMENT**

- **By signing below, I acknowledge an understanding of the following declarations:**
  - **Review of Requirements.** I declare, under penalty of making a false statement, that I have read and understand the statements and requirements of this application.
  - **Conditions of Approval.** I understand and will comply with the following conditions of approval, and I understand that the solar energy system will not receive a final approval until all of the said requirements and conditions have been completed:
    - The requirements of Section 1 of this application are hereby incorporated as conditions of approval, unless expressly and individually waived in writing by the City of Lakewood.
    - The solar energy system shall conform to the provisions and requirements of the County of Los Angeles Building, Electrical, Mechanical, and Plumbing Codes.
  - **Construction.** Hours and days of construction are limited to the following
    - Monday to Saturday: 7am to 7pm
    - Sunday: 9am to 7pm
  - **Permit and Plan Adherence.**
    - No work of any type shall take place unless all required permits are issued.
    - The undersigned warrant that the plans submitted for review in connection with this application are complete and accurate. Approval of the submitted plans is subject to the applicant having submitted accurate dimensions and information. If, during construction, it is found that the approved plans did not have accurate dimensions and/or information, the City of Lakewood may require the work to cease until revised, accurate plans are submitted to the Community Development Department for review in accordance with the requirements set forth herein.
    - All improvements shall be constructed in accordance with the approved plans. If, during construction, modifications or deviations from the approved plans are deemed necessary, any and all such modifications shall be submitted in the form of revised plans to the Community Development Department for review in accordance with the requirements set forth herein. No modification or deviation shall proceed without prior written approval by the Community Development Department. If these requirements are violated, the City of Lakewood may require the work to be completely removed and reconstructed in accordance with the approved plans.
  - **Penalties for Violation.** A violation of the statements and requirements of the Municipal Code may constitute an infraction punishable pursuant to Section 1200 of the Lakewood Municipal Code.

**I acknowledge and understand the declarations contained in Section 3 above.**

**Homeowner's signature:** \_\_\_\_\_ **Date:** \_\_\_\_\_

**Contractor's signature:** \_\_\_\_\_ **Date:** \_\_\_\_\_

**Property Address:** \_\_\_\_\_

## EXHIBIT A: VERTICAL CONDUIT RUN ILLUSTRATION

This exhibit is for illustrative purposes only. Submitted drawings must reflect actual site conditions

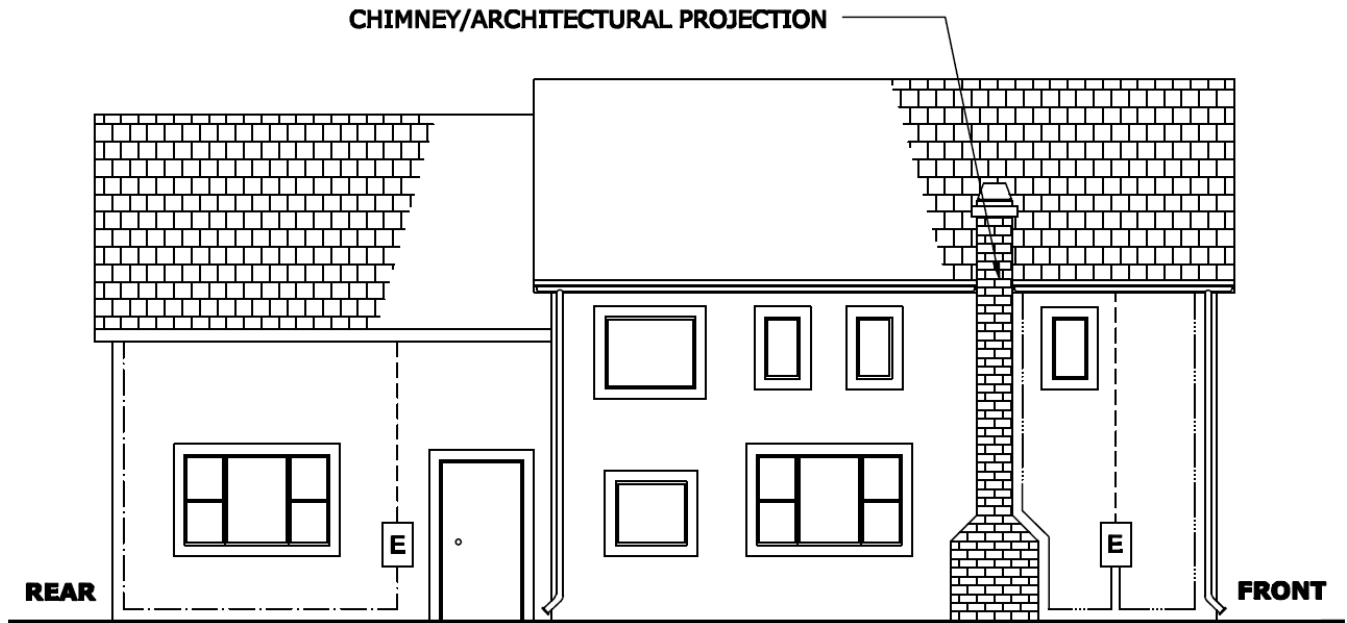

### LEGEND

- PREFERRED CONDUIT RUN
- - - - ACCEPTABLE CONDUIT RUN
- · · · DISCOURAGED CONDUIT RUN: NOT PERMITTED  
IF OTHER FEASIBLE ALTERNATIVES EXIST

**E** EQUIPMENT BOX

## EXHIBIT B: SOLAR PANEL SCREEN ILLUSTRATION FOR FLAT ROOF INSTALLATIONS

This exhibit is for illustrative purposes only. Submitted drawings must reflect actual site conditions.

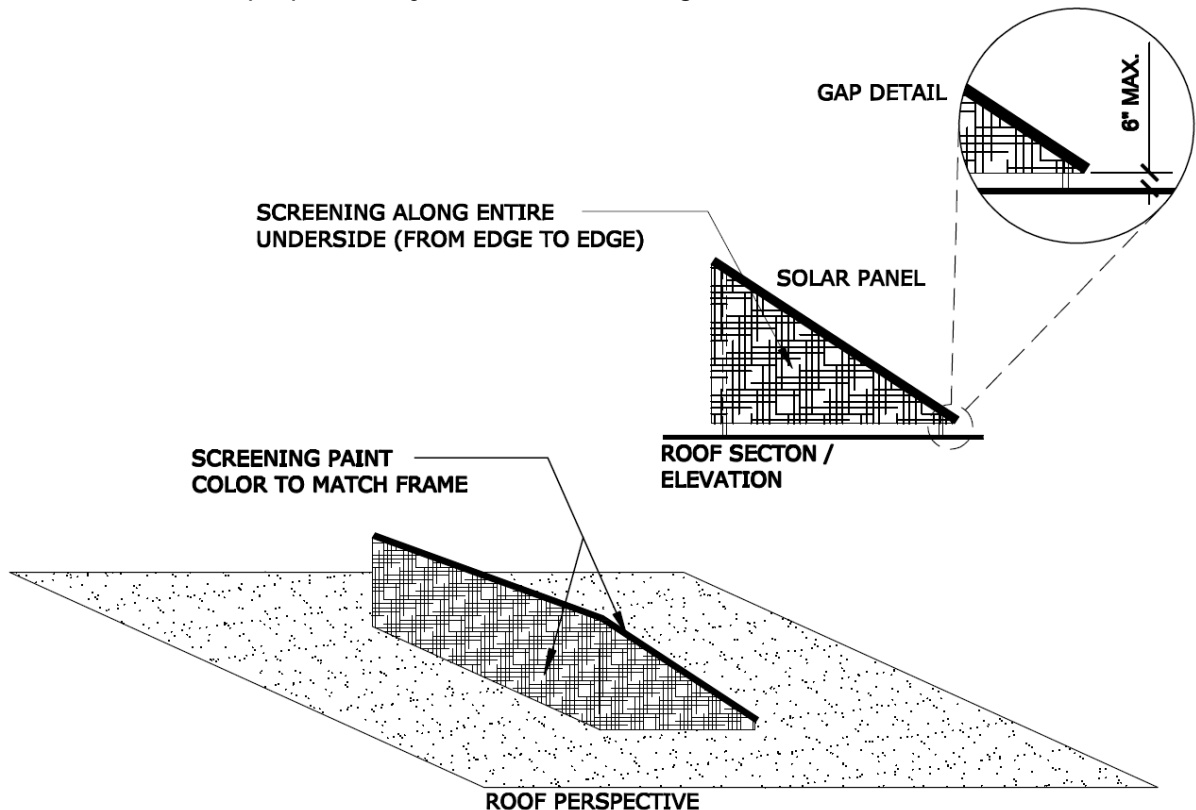

# EXHIBIT C: EXAMPLE STANDARD ELECTRIC DIAGRAM FOR SMALL-SCALE, SINGLE-PHASE PV SYSTEM

EQUIPMENT SCHEDULE		NOTES
TAG	DESCRIPTION	PART NUMBER
1	SOLAR PV MODULE	
2	PV ARRAY	
3	J-BOX (IF USED)	
4	COMBINER (IF USED)	
5	DC DISCONNECT	
6	DC/AC INVERTER	
7	AC DISCONNECT (IF USED)	
8	GEN METER (IF USED)	
9	SERVICE PANEL	

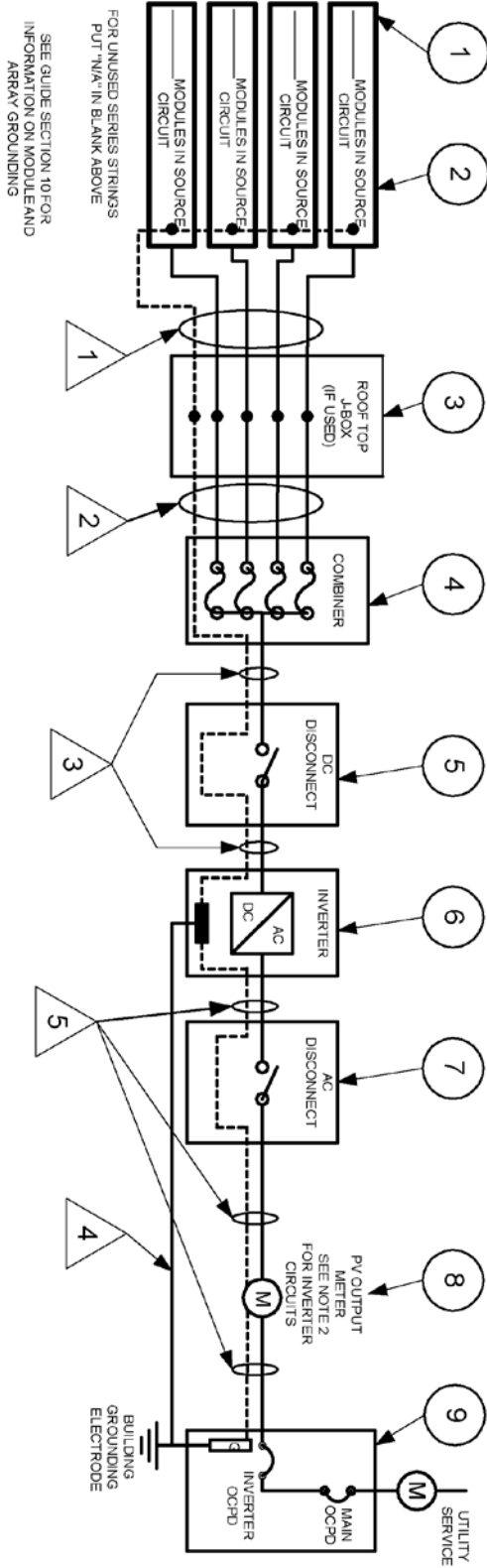

## STANDARD ELECTRICAL DIAGRAM FOR SMALL-SCALE, SINGLE-PHASE PV SYSTEMS

CONDUIT AND CONDUCTOR SCHEDULE			
TAG	DESCRIPTION OF CONDUCTOR TYPE	Conduit Gauge	# of Conductors
1	USE 2 OR PV WIRE (UF, SE, USE)		
2	BARE COPPER EQ. GND. COND. (EGC)		
3	THWN-2 OR XHHW-2 (circle one)		
4	INSULATED EGC		
5	DC GROUNDING ELECTRODE COND.		
	THWN-2 OR XHHW-2 (circle one)		
	INSULATED EGC		

**SITE NAME:** \_\_\_\_\_

**SITE ADDRESS:** \_\_\_\_\_

**SYSTEM AC SIZE:** \_\_\_\_\_

**CONTRACTOR / ENG. NAME:** \_\_\_\_\_

**CONTRACTOR / ENG. ADDRESS:** \_\_\_\_\_

**CONTRACTOR / ENG. LIC #:** \_\_\_\_\_

**DRAWN BY:** \_\_\_\_\_

**DATE:** \_\_\_\_\_

**EXPIRATION DATE:** \_\_\_\_\_

**DRAWING NO.:** \_\_\_\_\_

**EXHIBIT D: EXAMPLE STANDARD ELECTRIC DIAGRAM FOR SMALL-SCALE, SINGLE-PHASE PV SYSTEM CONT.**

PV MODULE RATINGS	
MODULE MAKE	
MODULE MODEL	
MAX. POWER POINT CURRENT (Imp)	
MAX. POWER POINT VOLTAGE (Vmp)	
OPEN-CIRCUIT VOLTAGE (Voc)	
SHORT-CIRCUIT CURRENT (Isc)	
MAX. SERIES FUSE (OCPPD)	
MAX. POWER (Pmax)	
MAX. VOLTAGE (Typ 600 VDC)	

NOTES FOR ALL DRAWINGS  
 OCPD=OVERCURRENT PROTECTION DEVICE  
 NATIONAL ELECTRICAL CODE REFERENCES  
 SHOWN AS (NEC XXX.XX)

INVERTER RATINGS	
INVERTER MAKE	
INVERTER MODEL	
MAX. DC VOLT RATING	
MAX POWER @48°C	
NOMINAL AC VOLTAGE	
MAX AC CURRENT	
MAX OCPD	

SIGNS	
SIGN FOR DC DISCONNECT	
PHOTOVOLTAIC POWER SOURCE	
RATED MPP CURRENT	
RATED MPP VOLTAGE	
MAX. SYSTEM VOLTAGE	
MAX CIRCUIT CURRENT	
WARNING ELECTRICAL SHOCK HAZARD-LINE AND LOAD MAY BE ENERGIZED IN OPEN POSITION	
SIGN FOR INVERTER OCPD AND AC DISCONNECT (IF USED)	
AC POINT OF CONNECTION	
AC OUTPUT CURRENT	
NOMINAL AC VOLTAGE	

**NOTES FOR ARRAY CIRCUIT WIRING**

- 1) LOWEST EXPECT AMBIENT TEMPERATURE BASED ON ASHRAE MINIMUM MEAN EXTREME DRY BULB TEMPERATURE FOR ASHRAE LOCATION MOST SIMILAR TO INSTALLATION. LOWEST EXPECTED AMBIENT TEMP 0 °C
- 2) HIGHEST CONTINUOUS AMBIENT TEMPERATURE BASED ON ASHRAE HIGHEST MONTH 2% DRY BULB TEMPERATURE FOR ASHRAE LOCATION MOST SIMILAR TO INSTALLATION LOCATION. HIGHEST CONTINUOUS TEMPERATURE 34 °C
- 3) 2005 ASHRAE FUNDAMENTALS 2% DESIGN TEMPERATURES DO NOT EXCEED 47°C N THE UNITED STATES (PALM SPRINGS, CA IS 44.1°C). FOR LESS THAN 9 CURRENT- CARRYING CONDUCTORS IN ROOF-MOUNTED SUNLIT CONDUIT AT LEAST 1/2" ABOVE ROOF AND USING THE OUTDOOR DESIGN TEMPERATURE OF 47°C OR LESS (ALL OF UNITED STATES).
  - a) 12AWG 90°C CONDUCTORS ARE GENERALLY ACCEPTABLE FOR MODULES WITH Isc OF 7.68 AMPS OR LESS WHEN PROTECTED BY A 12 AMP OR SMALLER FUSE
  - b) 10 AWG 90°C CONDUCTORS ARE GENERALLY ACCEPTABLE FOR MODULES WITH Isc OF 9.6 AMPS OR LESS WHEN PROTECTED BY A 15 AMP OR SMALLER FUSE

**NOTES FOR INVERTER CIRCUITS**

- 1) IF UTILITY REQUIRES A VISIBLE-BREAK SWITCH, DOES THIS SWITCH MEET THE REQUIREMENT? YES / NO (CIRCLE ONE)
- 2) IF GENERATION METER REQUIRED, DOES THIS METER SOCKET MEET THE REQUIREMENT? YES / NO (CIRCLE ONE)
- 3) SIZE PHOTOVOLTAIC POWER SOURCE (DC) CONDUCTOR S BASED ON MAX CURRENT ON 690.53 SIGN OR OCPD RATING AT DISCONNECT (IF SUPPLIED)
- 4) SIZE INVERTER OUTPUT CIRCUIT (AC) CONDUCTORS ACCORDING TO INVERTER OCPD AMP RATING
- 5) TOTAL OF \_\_\_\_\_ INVERTER OCPD(S), ONE FOR EACH INVERTER. DOES TOTAL SUPPLY BREAKERS COMPLY WITH 120% BUSBAR EXCEPTION IN 690.64(B)(2)(a)? YES / NO (CIRCLE ONE)

**STANDARD ELECTRICAL DIAGRAM FOR SMALL-SCALE, SINGLE-PHASE PV SYSTEMS**

SITE NAME:	
SITE ADDRESS:	
SYSTEM AC SIZE:	
CONTRACTOR / ENG. NAME:	
CONTRACTOR / ENG. ADDRESS:	
CONTRACTOR / ENG. LIC # :	
DRAWN BY:	DATE:
	EXPIRATION DATE:
DRAWING NO:	

**NOTE:** The scope of the project may require additional permits to be issued. Applications for Building, Electrical, Mechanical, and Plumbing permits can be downloaded from the City of Lakewood's website ([www.lakewoodcity.org/services/forms/default.asp](http://www.lakewoodcity.org/services/forms/default.asp)) or can be requested by phone or in person at the Building and Safety Counter in Lakewood City Hall.

The Building and Safety Division is open Monday-Thursday, 7:00am – 5:30pm and from 7:00am – 5:00pm Friday (City Hall is [closed alternating Fridays](#)).

If you wish to submit this and other Building and Safety permit applications electronically, you can email it to [Service1@lakewoodcity.org](mailto:Service1@lakewoodcity.org) or fax it to 562-866-0505.

Plans may also be **submitted electronically** through the Los Angeles County Department of Public Works Building and Safety Online Plan Check ([BSOP website](#)). We have a helpful [FAQ on electronic plan check services](#) that explains what electronic plan check is. For more detailed instructions on submitting for electronic plan check, please click [here](#). Lastly, we have a handy step-by-step visual guide for electronic plan check available [here](#). If you have any further questions, please contact the Plan Check Engineer at 562-866-9771, extension 2354.

If you have any questions, please contact the City of Lakewood Building and Safety Division at 562-866-9771 x2350 for further assistance.



**CITY OF LAKEWOOD**  
 Building and Safety Division  
 5050 Clark Avenue, Lakewood, CA 90712  
 (562) 866-9771, Extension 2350

**Disclaimer:** Permits are public records and may be posted to the Internet for Public review.  
 Please fill out all applicable fields

**APPLICATION FOR SMALL-SCALE SOLAR ENERGY PERMIT**

**PROJECT DESCRIPTION**

Address:		
Assessor Parcel Number:	Cross Street:	
Tenant/Project Name:		
Description of Work:		

**PROPERTY OWNER**

Name:		Owner-Builder: <input type="checkbox"/> Yes <input type="checkbox"/> No
Address:		Phone:
City:	State:	Zip Code:
E-mail:		Fax:

**APPLICANT INFORMATION (IF DIFFERENT FROM OWNER)**

Name:		E-mail:
Address:		Phone:
City:	State:	Zip Code:

**CONTRACTOR INFORMATION**

Name:		E-mail:
Address:		Phone:
City:	State:	Zip Code:
State License #:	Class:	Exp. Date:
Workers Compensation Carrier:	Policy #:	Exp: Date

**ARCHITECT/ENGINEER/DESIGNER INFORMATION**

Name:		
Address:		E-mail:
City:	State:	Zip Code:
State License #:	Exp. Date:	Phone:

I, the applicant/owner of the property located as noted as project address, acknowledge that I am aware approval from the City of Lakewood Community Development Department, Fire Department, Health Department, and any other agencies indicated on the agency referral form are required prior to the issuance of the building/grading permit. I hereby choose to submit plans for building/grading plan check prior to obtaining the necessary approvals of the agencies provided on the agency referral form. Furthermore, I am aware that if the building/grading plans have been reviewed and I cannot obtain the necessary approvals from the other agencies, the fees paid to Building and Safety Division for plans will be forfeited. I understand that additional plan check fees will apply if the plans submitted are modified in order to obtain approvals from other agencies. Also, plan check is valid for one year; additional fees may be required after one year for renewal.

Applicant/Owner Signature: \_\_\_\_\_ Date: \_\_\_\_\_



## SOLAR ENERGY SYSTEM INFORMATION

Proposed Use For Solar Energy System: <input type="checkbox"/> Electricity (Photovoltaic) <input type="checkbox"/> Pool/Spa <input type="checkbox"/> Space Heating	<input type="checkbox"/> Water Heater <input type="checkbox"/> Other: _____ _____
---	---

System Manufacturer:

System Unit Name:

Existing Roof Area (sq. ft.):

Area of System (sq. ft.):

Number of Panels:

Number of kW:

Construction Cost (materials & labor):

Landuse Type:     Residential     Commercial

Special Conditions:

**NOTE:** The scope of the project may require additional permits to be issued. Applications for Building, Electrical, Mechanical, and Plumbing permits can be downloaded from the City of Lakewood's website ([www.lakewoodcity.org/services/forms/default.asp](http://www.lakewoodcity.org/services/forms/default.asp)) or can be requested by phone or in person at the Building and Safety Counter in Lakewood City Hall.

The Building and Safety Division is open Monday-Thursday, 7:00am – 5:30pm and from 7:00am – 5:00pm Friday (City Hall is [closed alternating Fridays](#)).

If you wish to submit this and other Building and Safety permit applications electronically, you can email it to [Service1@lakewoodcity.org](mailto:Service1@lakewoodcity.org) or fax it to 562-866-0505.

Plans may also be **submitted electronically** through the Los Angeles County Department of Public Works Building and Safety Online Plan Check ([BSOP website](#)). We have a helpful [FAQ on electronic plan check services](#) that explains what electronic plan check is. For more detailed instructions on submitting for electronic plan check, please click [here](#). Lastly, we have a handy step-by-step visual guide for electronic plan check available [here](#). If you have any further questions, please contact the Plan Check Engineer at 562-866-9771, extension 2354.

If you have any questions, please contact the City of Lakewood Building and Safety Division at 562-866-9771 x2350 for further assistance.